

Guidance on regulations for
the

Transport of Infectious
Substances

2005

Guidance on regulations for
the

Transport of Infectious Substances

2005



**World Health
Organization**

Communicable Disease Surveillance and Response

Acknowledgement

The extracts from the Recommendations on the *Transport of Dangerous Goods, Model Regulations*, 13th revised edition, New York and Geneva, United Nations, 2003, and 14th revised edition, New York and Geneva, United Nations, 2005 are reproduced by kind permission of the United Nations.

© World Health Organization 2005

All rights reserved.

The designations employed and the presentation of the material in this publication do not imply the expression of any opinion whatsoever on the part of the World Health Organization concerning the legal status of any country, territory, city or area or of its authorities, or concerning the delimitation of its frontiers or boundaries. Dotted lines on maps represent approximate border lines for which there may not yet be full agreement.

The mention of specific companies or of certain manufacturers' products does not imply that they are endorsed or recommended by the World Health Organization in preference to others of a similar nature that are not mentioned. Errors and omissions excepted, the names of proprietary products are distinguished by initial capital letters.

All reasonable precautions have been taken by WHO to verify the information contained in this publication. However, the published material is being distributed without warranty of any kind, either express or implied. The responsibility for the interpretation and use of the material lies with the reader. In no event shall the World Health Organization be liable for damages arising from its use.

Contents

Introduction	1
International regulations.....	1
National regulations	2
Definitions and classification.....	2
Infectious substances.....	2
Cultures (laboratory stocks)	3
Patient specimens	4
Genetically modified microorganisms and organisms	4
Medical or clinical wastes	4
Exemptions.....	4
General preparation of shipments for transport.....	5
Basic triple packaging system	6
Packaging, labelling and documentation requirements for infectious substances in Category A ..	6
Packaging	6
Marking	8
Labelling	8
Documentation	10
Packaging, labelling and documentation requirements for infectious substances in Category B	12
Packaging	12
Marking	13
Documentation	13
Overpacks	14
Refrigerants	14
Training.....	15
Recommendations for countries that have not adopted the United Nations system	15
Transport planning	15
The shipper (sender, consignor)	16
The carrier	16
The receiver (consignee)	16
Requirements for air mail	17
Spill clean-up procedure.....	17
Incident reporting	18
Annex 1 Additional information on the United Nations System for the Transport of Dangerous Goods.....	19
Annex 2 Examples of infectious substances included in Category A.....	20
Annex 3 Packing Instruction P620	22
Annex 4 Packing Instruction P650	23
Annex 5 Flowchart for the classification of infectious substances and patient specimens	26

Introduction

These guidelines provide practical guidance to facilitate compliance with current international regulations for the transport of infectious substances and patient specimens by all modes of transport, both nationally and internationally, and include the changes that apply from 1 January 2005. They replace the guidelines issued by the World Health Organization (WHO) in 1997 (document WHO/EMC/97.3). This publication, however, does not replace national and international transport regulations.

The latest regulations are based on a completely new system and are no longer related to the Risk Group concept used until the end of 2004. The rationale for the new system is set out in document WHO/CDS/CSRL/LYO/2004.9 entitled *Background to the amendments adopted in the 13th revision of the United Nations Model Regulations guiding the transport of infectious substances* (http://www.who.int/csr/resources/publications/WHO_CDS_CSR_LYO_2004_9/en/).

The following guidelines provide information for classifying infectious substances for transportation and ensuring their safe packaging. They stress the importance of developing a working relationship between those involved – the sender, the carrier and the receiver – in order to provide for safe and expeditious transport of these materials.

Postal, airline and other transport industry personnel have concerns about the possibility of becoming infected as the result of exposure to infectious microorganisms that may escape from broken, leaking or improperly packaged material. The packaging of infectious substances for transport must therefore be designed to minimize the potential for damage during transport. In addition, the packaging must ensure the integrity of the materials and so, in turn, timely and accurate processing of specimens.

There are no recorded cases of illness attributable to the release of infectious substances or diagnostic specimens during transport, although there are reported incidents of damage to improperly and sometimes even properly packaged materials. The shipment of unmarked and unidentified infectious substances, improperly packaged, obviously increases the overall potential for exposure to all persons. Damage to packaging also means that samples dispatched for analysis, generally an urgent task, are unlikely to arrive at their destination on time.

International regulations

The international regulations for the transport of infectious substances by any mode of transport are based upon the Recommendations made by the Committee of Experts on the Transport of Dangerous Goods (UNCETDG), a committee of the United Nations Economic and Social Council. The Recommendations are presented in the form of Model Regulations. The United Nations Model Regulations are reflected in international law through international modal agreements (links to further information are provided in Annex 1):

Air The *Technical Instructions for the Safe Transport of Dangerous Goods by Air* published by the International Civil Aviation Organization (ICAO) are the legally binding international regulations. The International Air Transport Association (IATA) publishes Dangerous Goods Regulations (DGR) that incorporate the ICAO provisions and may add further restrictions (where necessary such restrictions are included in these guidelines). The ICAO rules apply on all international flights. For national flights, i.e. flights within one country, national civil aviation authorities apply national legislation. This is normally based on the ICAO provisions, but may incorporate variations. State and operator variations are published in the ICAO Technical Instructions and in the IATA Dangerous Goods Regulations.

- Rail** Regulations concerning the *International Carriage of Dangerous Goods by Rail* (RID) apply to countries in Europe, the Middle East and North Africa. RID also applies to domestic transport in the 25 countries of the European Union through Council Directive 96/49/EC.
- Road** The *European Agreement concerning the International Carriage of Dangerous Goods by Road* (ADR) applies to 40 countries. In addition, modified versions of the convention are being used by countries in South America and South-East Asia. ADR also applies to domestic transport in the 25 countries of the European Union through Council Directives 94/55/EC.
- Sea** The *International Maritime Dangerous Goods Code* published by the International Maritime Organization (IMO) is of mandatory application for all 155 contracting parties to the International Convention for the Safety of Life at Sea (SOLAS).
- Post** The *Letter post manual* published by the Universal Postal Union (UPU) reflects the United Nations Recommendations using the ICAO provisions as the basis for shipments.

The World Health Organization serves in an advisory capacity to UNCETDG and ICAO.

National regulations

Many countries adopt the United Nations Model Regulations in their entirety to stand as their national dangerous goods legislation. Some countries apply variations. National authorities should provide details of their own national requirements.

Note: These guidelines are based on the 13th revised edition of the United Nations Recommendations on the Transport of Dangerous Goods, the text of which is reflected in the 2005 editions of the international modal regulations, and in many sets of national legislation. In December 2004, UNCETDG agreed on further changes for the 14th edition. These changes do not come into force until 2007. However, some of them are covered in these guidelines as they are being permitted as options for air transport between 2005 and 2007, when they become mandatory. Shippers of infectious substances should check carefully whether such options are also permitted for land transport in the countries of origin and destination. If, in the future, further modifications are made to the section of the United Nations Recommendations that deals with infectious substances and patient specimens, the WHO guidelines will be updated accordingly.

Definitions and classification

In describing transport safety measures, the terms “infectious substances” and “infectious materials” are considered to be synonymous. The term “infectious substances” is used in this document. Text reproduced from the United Nations Model Regulations is italicized.

Infectious substances

For the purposes of transport, infectious substances are defined as substances which are known or are reasonably expected to contain pathogens. Pathogens are defined as microorganisms (including bacteria, viruses, rickettsiae, parasites, fungi) and other agents such as prions, which can cause disease in humans or animals. The definition is applied to all specimens except those explicitly excluded (see below). Infectious substances are divided into two categories.

Infectious substance, Category A

An infectious substance which is transported in a form that, when exposure to it occurs, is capable of causing permanent disability, life-threatening or fatal disease in otherwise healthy humans or animals. Indicative examples of substances that meet these criteria are given in the table in Annex 2.

NOTE: *An exposure occurs when an infectious substance is released outside of the protective packaging, resulting in physical contact with humans or animals.*

- (a) *Infectious substances meeting these criteria which cause disease in humans or both in humans and animals shall be assigned to United Nations number UN 2814. Infectious substances which cause disease only in animals shall be assigned to UN 2900.*

Dangerous goods are assigned UN numbers and proper shipping names according to their hazard classification and their composition. Proper shipping names are used to clearly identify the dangerous article or substance.

- (b) *Assignment to UN 2814 or UN 2900 shall be based on the known medical history and symptoms of the source human or animal, endemic local conditions, or professional judgement concerning individual circumstances of the source human or animal.*

NOTE 1: *The proper shipping name of UN 2814 is INFECTIOUS SUBSTANCE, AFFECTING HUMANS. The proper shipping name for UN 2900 is INFECTIOUS SUBSTANCE, AFFECTING ANIMALS only.*

NOTE 2: *The table in Annex 2 is not exhaustive. Infectious substances, including new or emerging pathogens, which do not appear in the table but which meet the same criteria shall be assigned to Category A. In addition, if there is doubt as to whether or not a substance meets the criteria it shall be included in Category A.*

NOTE 3: *In the table in Annex 2, the microorganisms written in italics are bacteria, mycoplasmas, rickettsiae or fungi.*

Infectious substance, Category B

An infectious substance which does not meet the criteria for inclusion in Category A. Infectious substances in Category B shall be assigned to UN 3373.

NOTE: *The proper shipping name of UN 3373 is “DIAGNOSTIC SPECIMENS” or “CLINICAL SPECIMENS”.*

Note: From 1 January 2007, the shipping name “DIAGNOSTIC SPECIMENS” or “CLINICAL SPECIMENS” will be replaced by “BIOLOGICAL SUBSTANCE, CATEGORY B”. However, air transport authorities are willing to accept the use of the new shipping name immediately and, as the shipping name is not used for other modes of transport, there will be no conflict if this new name is chosen before the mandatory date.

Cultures (laboratory stocks)

Cultures are the result of a process by which pathogens are amplified and propagated in order to generate high concentration, thereby increasing the risk of infection when exposure to them occurs. This definition refers to cultures prepared for the intentional generation of pathogens and does not include cultures intended for diagnostic and clinical purposes.

The following revision of the definition has been adopted for the 14th edition of the United Nations Model Regulations. ICAO has approved the application of this new text for air transport from 2005, as described in the Addendum Doc 9284-AN/905 published in March 2005:

Cultures are the result of a process by which pathogens are intentionally propagated. This definition does not include human or animal patient specimens as defined below. Cultures may be classified as Category A or Category B, depending on the microorganism concerned.

The following additional definition has been adopted for the 14th edition of the United Nations Model Regulations. ICAO has approved the application of this new text for air transport from 2005, as described in the Addendum Doc 9284-AN/905 published in March 2005:

Patient specimens

These are human or animal materials, collected directly from humans or animals, including, but not limited to, excreta, secreta, blood and its components, tissue and tissue fluid swabs, and body parts being transported for purposes such as research, diagnosis, investigational activities, disease treatment and prevention.

Genetically modified microorganisms and organisms

Genetically modified microorganisms and organisms are microorganisms and organisms in which genetic material has been purposely altered through genetic engineering in a way that does not occur naturally. Those genetically modified microorganisms and organisms that do not meet the definition of an infectious substance shall be assigned to UN 3245 and shipped following Packing Instruction P904 (ICAO/IATA PI913) – this is not considered further in these guidelines.

Medical or clinical wastes

Medical or clinical wastes are wastes derived from the medical treatment of animals or humans or from bio-research. Medical or clinical wastes containing Category A infectious substances shall be assigned to UN 2814 or UN 2900 as appropriate. Medical or clinical wastes containing Category B infectious substances, or which are reasonably believed to have a low probability of containing infectious substances, shall be assigned to UN 3291 and shipped following Packing Instruction P621 (ICAO/IATA PI622) – this is not considered further in these guidelines.

Exemptions

Because of the low hazard they present, the following substances of biological origin are exempted from dangerous goods requirements and regulations:

- substances that do not contain infectious substances or will not cause disease in humans or animals
- substances containing microorganisms that are not pathogenic to humans or animals
- substances in a form in which any pathogens present have been neutralized or inactivated such that they no longer pose a health risk
- environmental samples (including food and water samples) that are not considered to pose a significant risk of infection
- blood and/or blood components collected and shipped for the purposes of transfusion and/or transplantation
- dried blood spots and faecal occult blood screening tests
- decontaminated medical or clinical wastes.

The following additional conditional exemptions have been adopted for the 14th edition of the United Nations Model Regulations. This text is likely to become applicable in 2005 for the air mode, but only in 2007 for the other modes of transport. The following is an extract from the 14th edition of the United Nations Model Regulations.

Exempt human/animal specimens

Human or animal specimens for which there is minimal likelihood that pathogens are present are not subject to these Regulation if the specimen is transported in a packaging which will prevent any leakage and which is marked with the words “Exempt human specimen” or “Exempt animal specimen”, as appropriate. The packaging should meet the following conditions:

The packaging should consist of three components:

- (i) a leak-proof primary receptacle(s);*
- (ii) a leak-proof secondary packaging; and*
- (iii) an outer packaging of adequate strength for its capacity, mass and intended use, and with at least one surface having minimum dimensions of 100 mm × 100 mm;*

For liquids, absorbent material in sufficient quantity to absorb the entire contents should be placed between the primary receptacle(s) and the secondary packaging so that, during transport, any release or leak of a liquid substance will not reach the outer packaging and will not compromise the integrity of the cushioning material;

When multiple fragile primary receptacles are placed in a single secondary packaging, they should be either individually wrapped or separated to prevent contact between them.

If such a packaging is used it should be marked “Exempt human specimen” or “Exempt animal specimen”, as appropriate.

NOTE: *An element of professional judgment is required to determine if a substance is exempt under this paragraph. That judgment should be based on the known medical history, symptoms and individual circumstances of the source, human or animal, and endemic local conditions. Examples of specimens which may be transported under this paragraph include the blood or urine tests to monitor cholesterol levels, blood glucose levels, hormone levels, or prostate specific antibodies (PSA); those required to monitor organ function such as heart, liver or kidney function for humans or animals with non-infectious diseases, or therapeutic drug monitoring; those conducted for insurance or employment purposes and are intended to determine the presence of drugs or alcohol; pregnancy test; biopsies to detect cancer; and antibody detection in humans or animals.*

Note: Air transport changes in 2005. ICAO has decided that it will make the above provisions mandatory in 2005 when they issue a second Addendum to the 2005/06 edition of the Technical Instructions in the summer of 2005. The addendum will make the above extract from the United Nations Recommendations mandatory, which means that if a medical judgement is made that the sample to be sent is not Category A or Category B then it may be sent in the packaging described above.

General preparation of shipments for transport

Because of the differences in the hazards posed by Category A infectious substances (UN 2814 and UN 2900) and Category B infectious substances (UN 3373), there are variations in the packaging, labelling and documentation requirements for the two categories. The packaging requirements are

determined by UNCETDG and are set out as Packing Instructions P620 (PI602 for ICAO/IATA regulations) and P650, reproduced in Annexes 3 and 4, respectively. The requirements are subject to change and regular upgrade by the organizations mentioned. The current packaging requirements are described below.

Note 1: Hand carriage of Category A and Category B infectious substances and transport of these materials in diplomatic pouches are strictly prohibited by international air carriers.

Note 2: Inner packagings containing infectious substances shall not be consolidated with inner packagings containing unrelated types of goods.

Shippers of infectious substances shall ensure that packages are prepared in such a manner that they arrive at their destination in good condition and present no hazard to persons or animals during transport.

Basic triple packaging system

This system of packaging shall be used for all infectious substances. It consists of three layers as follows.

- Primary receptacle. A primary watertight, leak-proof receptacle containing the specimen. The receptacle is packaged with enough absorbent material to absorb all fluid in case of breakage.
- Secondary packaging. A second durable, watertight, leak-proof packaging to enclose and protect the primary receptacle(s). Several cushioned primary receptacles may be placed in one secondary packaging, but sufficient additional absorbent material shall be used to absorb all fluid in case of breakage.
- Outer packaging. Secondary packagings are placed in outer shipping packagings with suitable cushioning material. Outer packagings protect their contents from outside influences, such as physical damage, while in transit. The smallest overall external dimension shall be 10x10 cm.

Each completed package is normally required to be marked, labelled and accompanied with appropriate shipping documents (as applicable). The requirements for these aspects are described below.

Packaging, labelling and documentation requirements for infectious substances in Category A

Packaging

The basic triple packaging system is used with the following additional specifications.

Infectious substances in Category A may only be transported in packaging that meets the United Nations class 6.2 specifications and complies with Packing Instruction P620 (PI602) (see Annex 3; Figure 1). This ensures that strict performance criteria are met; tests for compliance with these criteria include a 9-metre drop test, a puncture test and a pressure test. The outer packaging shall bear the United Nations packaging specification marking (Figure 2), which indicates that the packaging has passed the performance tests to the satisfaction of the competent authority.

The primary receptacle or the secondary packaging shall be capable of withstanding a pressure differential of not less than 95 kPa. The United Nations packaging specification marking alone does not indicate that a test for this has been undertaken, and packaging users should ask their suppliers whether the completed package meets this requirement.

There is no comprehensive list of suppliers of packagings that comply with Packing Instruction P620 (PI602). However, an Internet search using a suitable international or national search engine usually provides appropriate information, as well as access to national regulations. Search phrases such as “UN packaging” and “UN infectious substance packaging” produce extensive results. Carriers and forwarding agents should also be able to supply details of local suppliers or local companies that can provide such information.

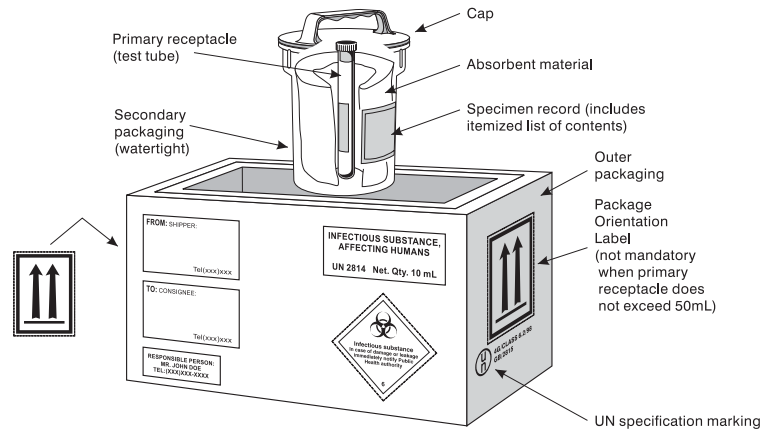

Figure 1. Example of triple packaging system for the packaging and labelling of Category A infectious substances (Figure kindly provided by IATA, Montreal, Canada)

	4G/Class 6.2/05/GB/2470
<p>This marking comprises:</p> <ul style="list-style-type: none"> • the United Nations packaging symbol • an indication of the type of packaging (in this example a fibreboard box (4G)) • an indication that the packaging has been specially tested to ensure that it meets the requirements for Category A infectious substances (Class 6.2) • the last two digits of the year of manufacture (in this example 2005) • the competent state authority that has authorized the allocation of the mark (in this example GB, signifying Great Britain) • the manufacturer's code specified by the competent authority (in this example 2470) <p>Users shall be provided with clear instructions as to how the package should be filled and prepared for transport.</p>	

Figure 2. Package specification marking for Category A infectious substances (UN 2814 and UN 2900)

The maximum net quantity of Category A infectious substances that can be contained in an outer shipping package is limited to 400 kg for solids and 450 l for liquids for surface transport (road, rail and sea). For air transport the limits per package are as follows:

- 50 ml or 50 g for passenger aircraft
- 4 l or 4 kg for cargo aircraft.

Any primary receptacle with a capacity of more than 50 ml shall be oriented in the outer packaging so that the closures are upwards. Orientation labels (“UP” arrows) shall be affixed to two opposite sides of the outer packaging.

Marking

Packages are marked to provide information about the contents of the package, the nature of the hazard, and the packaging standards applied. All markings on packages or overpacks shall be placed in such a way that they are clearly visible and not covered by any other label or marking. Each package shall display the following information on the outer packaging or the overpack.

- the shipper’s (sender’s, consignor’s) name and address
- the telephone number of a responsible person, knowledgeable about the shipment
- the receiver’s (consignee’s) name and address
- the United Nations number followed by the proper shipping name (UN 2814 “INFECTIOUS SUBSTANCES AFFECTING HUMANS” or UN 2900 “INFECTIOUS SUBSTANCES AFFECTING ANIMALS”, as appropriate). Technical names need not be shown on the package.
- temperature storage requirements (optional)
- when dry ice or liquid nitrogen is used: the technical name of the refrigerant, the appropriate United Nations number, and the net quantity

Labelling

There are two types of labels: (a) hazard labels in the form of a square set at an angle of 45° (diamond-shaped) are required for most dangerous goods in all classes; (b) handling labels in various shapes are required, either alone or in addition to hazard labels, for some dangerous goods. Specific hazard label(s) shall be affixed to the outside of each package for all dangerous goods to be shipped (unless specifically exempted). The hazard labels shown in Figures 3–7 are of importance for infectious substances in Category A:



Label name:	Infectious substance
Minimum dimensions:	100 × 100 mm
(for small packages:	50 × 50 mm)
No. of labels per package:	1
Colour:	Black and white

The words “INFECTIOUS SUBSTANCE” shall be shown. The statement “In case of damage or leakage immediately notify a Public Health Authority” is required in some countries.

Figure 3. Hazard label for Category A infectious substances and for genetically modified microorganisms and organisms that meet the definition of an infectious substance, Category A

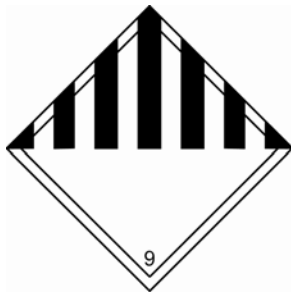

Label name:	Miscellaneous dangerous substances
Minimum dimensions:	100 × 100 mm
(for small packages:	50 × 50 mm)
No. of labels per package:	1
Colour:	Black and white

Figure 4. Hazard label for certain noninfectious genetically modified microorganisms and organisms (UN 3245) and for carbon dioxide, solid (dry ice) (UN 1845); substances packed in dry ice (see section on Refrigerants) shall bear this label in addition to the primary risk label (e.g. the label shown in Figure 3 for Category A infectious substances, the marking shown in Figure 10 for Category B infectious substances)



Label name:	Non flammable, non-toxic gas
Minimum dimensions:	100 × 100mm
(for small packages:	50 × 50 mm)
No. of labels per package:	1
Colour:	Green and white or green and black

Figure 5. Hazard label for liquid nitrogen; substances packed using liquid nitrogen (see section on Refrigerants) shall bear this label in addition to the primary risk label (e.g. the label shown in Figure 3 for Category A infectious substances, the marking shown in Figure 10 for Category B infectious substances)



Label name:	Cryogenic liquid
Minimum dimensions:	Standard A7: 74 × 105 mm
No. of labels per package:	1
Colour:	Green and white

Figure 6. Handling label for cryogenic liquids; for transport by air, where cryogenic liquids (deeply refrigerated liquefied gases) are used (see section on Refrigerants), this label shall be affixed to insulated vessels or flasks used as outer packaging in addition to the labels or markings shown in Figures 3, 5 and 10, as appropriate

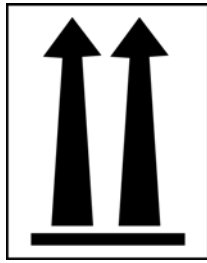

Label name:	Orientation label
Minimum dimensions:	Standard A7: 74 × 105 mm
No. per package:	2 on opposite sides
Colour:	Black and white or red and white

The words “THIS SIDE UP” or “THIS END UP” may also be displayed on the top cover of the package.

Figure 7. Orientation label to indicate position of closures on the primary receptacles; for the transport of quantities of liquid infectious substances in Category A that exceed 50 ml per package, this label shall be affixed to two opposite sides of the package with the arrows pointing in the right direction, in addition to the label shown in Figure 3

Instructions for the labelling of overpacks are given in the section on Overpacks.

Documentation

The following shipping documents are required.

To be prepared and signed by the shipper:

- for air: the shipper’s Declaration for Dangerous Goods (Figure 8 shows one example)
- a packing list/proforma invoice that includes the receiver’s address, the number of packages, detail of contents, weight, value (Note: for international transport, a minimal value shall be indicated, for customs purposes, if the items are supplied free of charge)
- an import and/or export permit and/or declaration if required.

To be prepared by the shipper or the shipper’s agent:

- an air waybill for air transport or equivalent documents for road, rail and sea journeys.

For UN 2814 and UN 2900, an itemized list of contents shall be enclosed between the secondary packaging and the outer packaging. When the infectious substance to be transported is unknown, but suspected of meeting the criteria for inclusion in category A and assignment to UN 2814 or UN 2900, the words “suspected Category A infectious substance” shall be shown, in parentheses, following the proper shipping name on the document inside the outer packaging.

SHIPPER'S DECLARATION FOR DANGEROUS GOODS						
Shipper Hôpital des enfants 5, Rue des Mimosas 05234 Rivière Fleurie - Primance Dr Bedikian tel +0789 456 123			Air Waybill No 543 7654 9876 Pag 1 of 1 Pages Shipper's Reference Number <i>(optional)</i>			
Consignee Laboratorios Biovirobact 5, Calle Escherichia 98675 Eproveta - Polotos Dr Guarguir tel +0520 36 009 832						
Two completed and signed copies of this Declaration must be handed to the operator.			WARNING Failure to comply in all respects with the applicable Dangerous Goods Regulations may be in breach of the applicable law, subject to legal penalties.			
TRANSPORT DETAILS This shipment is within the limitations prescribed for: <i>(delete non-applicable)</i>			Airport of Departure: VILLEBELLE			
PASSENGER AND CARGO AIRCRAFT		<input checked="" type="checkbox"/> CARGO AIRCRAFT ONLY				
Airport of Destination: VIALIS			Shipment type: <i>(delete non-applicable)</i> NON-RADIOACTIVE <input checked="" type="checkbox"/> RADIOACTIVE			
NATURE AND QUANTITY OF DANGEROUS GOODS						
Dangerous Goods Identification						
UN or ID No.	Proper Shipping Name	Class or Division (Subsidiary risk)	Packing Group	Quantity and type of packing	Packing Inst.	Authorization
UN 2814	Infectious substance, affecting humans, (Ebola virus)	6.2		50 mL	602	
UN 1845	Dry ice	9		20 kg All packed in one fibreboard box	904	
Additional Handling Information Emergency contact: Dr Bedikian Tel +0789 456 123						
I hereby declare that the contents of this consignment are fully and accurately described above by the proper shipping name, and are classified, packaged, marked and labelled/placarded, and are in all respects in proper condition for transport according to applicable international and national governmental regulations. I declare that all of the applicable air transport requirements have been met.				Name/Title of Signatory Dr Bedikian, Goods Receipt & Dispatch Place and Date Rivière Fleurie, 18 May 2005 Signature <i>(see warning above)</i>		

Figure 8. Example of a completed shipper's Declaration for Dangerous Goods

Packaging, labelling and documentation requirements for infectious substances in Category B

Packaging

The triple packaging system continues to apply, including for local surface transport. Testing documents are not required, however. It may be possible to source packagings locally rather than finding an authorized supplier, provided that the packaging manufacturer and the shipper can comply fully with the requirements of P650 (see Annex 4; Figure 9).

As for P620, there is no comprehensive list of suppliers of packagings that comply with Packing Instruction P650. However, an Internet search using a suitable international or national search engine usually provides appropriate information, as well as access to national regulations. Search phrases such as “UN packaging” and “UN infectious substance packaging” produce extensive results. Carriers and forwarding agents should also be able to supply details of local suppliers or local companies that can provide such information.

To ensure correct preparation for transport, packaging manufacturers and subsequent distributors shall provide clear instructions to the consignor or persons preparing packages (e.g. patients) on how the packaging should be filled and closed.

For surface transport there is no maximum quantity per package. For air transport:

- no primary receptacle shall exceed 1 l (for liquids) or 1 kg (for solids)
- the volume shipped per package shall not exceed 4 l or 4 kg.

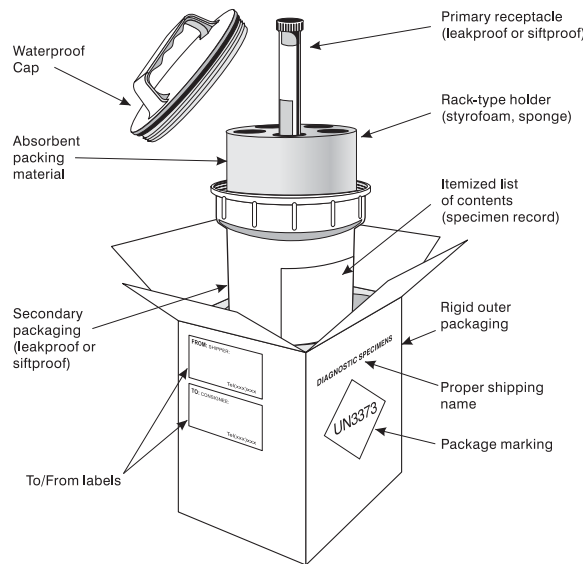

Figure 9. Example of the triple packaging system for the packing and labelling of Category B infectious substances (Figure kindly provided by IATA, Montreal, Canada)

Provided all the requirements of P650 are met, there are no other transport requirements. P650 incorporates all that is needed to make a shipment for Category B infectious substances.

Marking

Each package shall display the following information:

- for air: the shipper's (sender's, consignor's) name, address and telephone number
- for air: the telephone number of a responsible person, knowledgeable about the shipment
- the receiver's (consignee's) name, address and telephone number
- for air: the proper shipping name ("DIAGNOSTIC SPECIMENS" or "CLINICAL SPECIMENS" or "BIOLOGICAL SUBSTANCE, CATEGORY B")
- temperature storage requirements (optional).

The marking shown in Figure 10 is used for shipments of Category B infectious substances.



- Minimum dimension: the width of the line forming the square shall be at least 2 mm, and the letters and numbers shall be at least 6 mm high. For air transport, each side of the square shall have a length of at least 50 mm
- Colour: none specified, provided the mark is displayed on the external surface of the outer packaging on a background of contrasting colour and that it is clearly visible and legible
- For surface transport (by road, rail and sea): no other mark is required
- For air transport: the mark shall be shown but with the following additional information:
The words "DIAGNOSTIC SPECIMENS" or "CLINICAL SPECIMENS" in letters at least 6 mm high shall be displayed adjacent to the mark
From 2007 the name will be "BIOLOGICAL SUBSTANCE, CATEGORY B" for all modes of transport, but this shipping name can be used immediately without contravening the regulations

Figure 10. Marking for infectious substances of Category B and for genetically modified microorganisms or organisms that meet the definition of an infectious substance, Category B

Note: For air transport:

- When dry ice (solid carbon dioxide) is used (see section on Refrigerants), the label shown in Figure 4 shall be applied.
- For cryogenic liquids (see section on Refrigerants) the labels shown in Figures 5 and 6 shall also be affixed.

Documentation

Dangerous goods documentation (including a shipper's declaration) is not required for Category B infectious substances. The following shipping documents are required.

To be prepared and signed by the shipper (sender, consignor):

- for international shipments: a packing list/proforma invoice that includes the shipper's and the receiver's address, the number of packages, detail of contents, weight, value (Note: the statement "no commercial value" shall appear if the items are supplied free of charge)
- an import and/or export permit and/or declaration if required.

To be prepared by the shipper or the shipper's agent:

- an air waybill for air transport or equivalent documents for road, rail and sea journeys.

A flowchart to help with the classification of infectious substances and patient specimens is shown in Annex 5.

Overpacks

"Overpack" is the term used when several packages are combined to form one unit and sent to the same destination by a single shipper. When refrigerants are used to protect contents, the overpacks may comprise insulated vessels or flasks. Whenever an overpack is used, the required marks and labels shown on the outer packaging must be repeated on the outermost layer of the overpack. This requirement applies to infectious substances in Categories A and B. Overpacks are also required to be marked with the word "overpack".

Refrigerants

Refrigerants may be used to stabilize infectious substances in Categories A and B during transit.

Ice or dry ice shall be placed outside the secondary receptacle. Wet ice shall be placed in a leak-proof container; the outer packaging or overpack shall also be leak-proof. Dry ice must not be placed inside the primary or secondary receptacle because of the risk of explosions. A specially designed insulated packaging may be used to contain dry ice. The packaging must permit the release of carbon dioxide gas if dry ice is used. ICAO/IATA Packing Instruction 904 shall be observed.

The secondary receptacle shall be secured within the outer package to maintain the original orientation of the inner packages after the refrigerant has melted or dissipated.

If dry ice is used to ship infectious substances in Category A, the details shall appear on the shipper's Declaration for Dangerous Goods. In addition, the outermost packaging shall carry the hazard label for dry ice (see Figure 4) and the appropriate marking. If dry ice is used to ship infectious substances in Category B, the package shall be marked "Carbon dioxide, solid" or "Dry ice" - this is not considered further in these guidelines.

If liquid nitrogen is used as a refrigerant, special arrangements shall be made in advance with the carrier. Primary receptacles shall be capable of withstanding extremely low temperatures, and packaging and documentation requirements for liquid nitrogen shall be observed. In particular, the outermost packaging shall carry the hazard label for liquid nitrogen (see Figure 5). For air transport, the handling label for cryogenic liquids shall also be affixed (see Figure 6) – this is not considered further in these guidelines.

Training

The dangerous goods regulations require all personnel involved in transport to undergo appropriate training.

For the transport of Category A infectious substances, personnel must undergo training in accordance with the modal requirements. This can involve attendance at approved courses and passing examinations.

For the transport of Category B infectious substances there is a requirement that clear instructions on the use of the packaging are supplied to the user; this is regarded as sufficient “training” for the shipping of these substances. However, if such specimens are consigned with other dangerous goods (e.g. flammable liquids, radioactive materials, liquefied gases, etc.), then personnel must be trained in the proper procedures for their transport.

Training and awareness are important for all personnel involved in the transport of Category B infectious substances. Training of personnel, for example via consultation of guidance documents like this one, while not formally required by the modal regulations, is recommended and encouraged. Only through appropriate guidance and training can shippers ensure that the classification of the substance to be shipped is correct, and that proper packaging is selected and prepared. Carriers and other employers of transport workers should train their personnel in the appropriate procedures for recognizing and handling packages containing infectious substances and in how to address spills and protect themselves from exposure.

Recommendations for countries that have not adopted the United Nations system

The recommendations set out above apply wherever the United Nations system for the transport of infectious substances has been adopted. WHO encourages all countries to adopt this system, and recommends those that have not yet done so to follow its provisions. However, the principles described above are not intended to supersede national or local requirements.

Transport planning

It is the responsibility of the shipper to ensure the correct classification, packaging, labelling and documentation of all infectious substances destined for transport.

The efficient transport and transfer of infectious materials requires good coordination between the sender, the carrier and the receiver to ensure that the material is transported safely and arrives on time and in good condition. Such coordination depends upon well-established communications and a good working relationship between the three parties.

The carriage of any goods whether dangerous or not, is a commercial matter for a carrier. The dangerous goods rules described in these guidelines reflect governmental legal requirements. Indeed, different countries may have adopted State variations to the United Nations Model Regulations. In

addition, a carrier that does not wish to carry particular goods is under no legal obligation to do so. Many carriers (airlines, hauliers and shipping lines) are “private carriers” and have the right to refuse to carry goods or add additional requirements. In recent years it has become clear that some carriers are indeed refusing to carry certain goods or are adding extra conditions. Provided such conditions do not conflict with the legal requirements, this type of action is not illegal.

The IATA Dangerous Goods Regulations list the main carrier restrictions in force among airlines. Some airlines will not carry dangerous goods at all, while others will carry only a very limited range of goods. As carrier restrictions for the different modes of transport are not published centrally, harmonization between stakeholders is essential. The shipper (sender, consignor), carrier and the receiver (consignee) have specific responsibilities in ensuring successful transportation.

The shipper (sender, consignor)

- Makes advance arrangements with the receiver including investigating the need for import/export permits
- Makes advance arrangements with the carrier to ensure:
 - that the shipment will be accepted for appropriate transport
 - that the shipment (direct transport if possible) is undertaken by the most direct routing
- Prepares necessary documentation, including permits, dispatch and shipping documents
- Notifies the receiver of transportation arrangements once these have been made, well in advance of the expected arrival time.

The carrier

- Provides advice to the sender regarding the necessary shipping documents and instructions for their completion
- Provides advice to the sender about correct packaging
- Assists the sender in arranging the most direct routing and then confirms the routing
- Maintains and archives the documentation for shipment and transport.

The receiver (consignee)

- Obtains the necessary authorization(s) from national authorities for the importation of the material
- Provides the sender with the required import permit(s), letter(s) of authorization, or other document(s) required by the national authorities
- Arranges for the most timely and efficient collection on arrival
- Should acknowledge receipt to the sender.

Shipments should not be dispatched until:

- Advance arrangements have been made between the sender, carrier and receiver
- The receiver has confirmed with the national authorities that the material may be legally imported
- The receiver has confirmed that there will be no delay incurred in the delivery of the package to its destination.

Requirements for air mail

Infectious substances in Category A will not be accepted for shipment through postal services.

Infectious substances in Category B may be shipped by registered air mail, and the Universal Postal Union recommends the following procedure.

The basic triple packaging system is used with the same requirements as for other means of transport. The address label shall display the word “*Lettre*” or “Letter” and the green Customs Declaration Label for Postal Mail is required for international mailing. “DIAGNOSTIC SPECIMENS”, “CLINICAL SPECIMENS” or “BIOLOGICAL SUBSTANCE, CATEGORY B” shall be identified with the white diamond label with black letters “UN 3373” (see Figure 10).

Local/international restrictions may be in force. Prior contact should therefore be made with the national public operator to ascertain whether the packaged material will be accepted by the postal service in question.

Spill clean-up procedure

The appropriate response in the event of exposure to any infectious substance is to wash or disinfect the affected area as soon as possible, regardless of the agent. Even if an infectious substance comes into contact with non-intact skin, washing of the affected area with soap and water or with an antiseptic solution can reduce the risk of infection. Medical advice should be obtained any time there is a suspected exposure to infectious substances resulting from a damaged package. The following procedure for clean-up can be used for spills of all infectious substances including blood.

1. Wear gloves and protecting clothing, including face and eye protection if indicated.
2. Cover the spill with a cloth or paper towels to contain it.
3. Pour an appropriate disinfectant over the cloth or paper towels and the immediately surrounding area (5% bleach solutions are generally appropriate, but for spills on aircraft, quaternary ammonium disinfectants should be used).
4. Apply the disinfectant concentrically beginning at the outer margin of the spill area, working toward the centre.
5. After about 30 min, clear away the materials. If there is broken glass or other sharps are involved, use a dustpan or a piece of stiff cardboard to collect the materials and deposit them into a puncture-resistant container for disposal.
6. Clean and disinfect the area of the spillage (if necessary, repeat steps 2–5).
7. Dispose of contaminated materials into a leak-proof, puncture-resistant waste disposal container.
8. After successful disinfection, report the incident to the competent authority and inform them that the site has been decontaminated (see Incident reporting below).

Detailed information on disinfectants and their recommended use can be found in *Laboratory biosafety manual*, 3rd ed., Geneva, World Health Organization, 2004.

Incident reporting

No reports of infections resulting from transport-related exposures have been documented. There have been reports of the transmission of acute respiratory infections and tuberculosis associated with air travel, but these were attributed to direct person-to-person contact and not to packaging problems or shipping incidents.

Statistical data collected by a group of central laboratories showed the efficacy of packaging compliant with P650 and P620 in assuring that infectious substances are transported without leakage and loss of materials. For the 4.92 million primary containers shipped in 2003 to any of the worldwide regional offices of these central laboratories, just 106 breakages, 0.002% of the total number, were recorded. Moreover, the leakages that did occur were all contained by the absorbent material, and no damage to secondary containers or outer packagings was reported.

The various international modal regulations require the reporting of incidents to the relevant competent transport authorities in addition to the necessary health authorities. This applies to both categories of infectious substances, but particularly to those in Category A.

Annex 1

Additional information on the United Nations System for the Transport of Dangerous Goods

The United Nations dangerous goods web site provides comprehensive detail concerning the United Nations Recommendations on the Transport of Dangerous Goods. It also provides links to the modal agencies:

<http://www.unece.org/trans/danger/danger.htm>

The site below provides the full text of the United Nations Recommendations, which can be downloaded in PDF format. Readers wishing to see the text relating to the transport of infectious substances should download Part 2, Part 4 and Part 5 of the Recommendations:

http://www.unece.org/trans/danger/publi/unrec/rev13/13files_e.html

The site below provides the full text of the European Agreement concerning the International Carriage of Dangerous Goods by Road (ADR), which can be downloaded in PDF format. Readers wishing to study the text relating to the transport of infectious substances should download Part 2.2 (2.2.52 to 2.2.7), Part 4 Chapter 4.1 and Part 5:

<http://www.unece.org/trans/danger/publi/adr/adr2003/ContentsE.html>

Contracting parties to the various conventions for the transport of dangerous goods can be found on a number of web sites:

Air ICAO: http://www.icao.org/cgi/goto_m.pl?/cgi/statesDB4.pl?en

Rail RID: <http://www.otif.org/>. RID is primarily for the countries of Europe, North Africa and the Middle East. There are a number of countries (mainly Eastern Europe and Asia) that apply RID through the Organization for Cooperation of Railways (OSJD); details of RID membership can be found at http://www.otif.org/html/e/pres_cont_gouv_ferr.php

Road ADR: <http://www.unece.org/trans/danger/publi/adr/comp.htm> (lists competent authorities) and <http://www.unece.org/trans/danger/publi/adr/treaty.html> (lists contracting parties)

Sea IMO: <http://www.imo.org/home.asp>

Post UPU: <http://www.upu.int/> The Universal Postal Union develops recommendations on the transport of dangerous goods that are available at http://www.upu.int/acts/en/letter_post_manual.shtml

Annex 2

Examples of infectious substances included in Category A

The table provided below is an indicative list taken from the 13th edition of the United Nations Model Regulations. The air mode (ICAO) has anticipated the classification requirements that will be applicable for other modes in 2007. The relevant changes are indicated in the explanatory notes added to the table.

INDICATIVE EXAMPLES OF INFECTIOUS SUBSTANCES INCLUDED IN CATEGORY A IN ANY FORM UNLESS OTHERWISE INDICATED	
UN Number and Proper Shipping Name	Microorganism
UN 2814 Infectious substances affecting humans	<i>Bacillus anthracis</i> (cultures only)
	<i>Brucella abortus</i> (cultures only)
	<i>Brucella melitensis</i> (cultures only)
	<i>Brucella suis</i> (cultures only)
	<i>Burkholderia mallei</i> – <i>Pseudomonas mallei</i> – glanders (cultures only)
	<i>Burkholderia pseudomallei</i> – <i>Pseudomonas pseudomallei</i> (cultures only)
	<i>Chlamydia psittaci</i> – avian strains (cultures only)
	<i>Clostridium botulinum</i> (cultures only)
	<i>Coccidioides immitis</i> (cultures only)
	<i>Coxiella burnetii</i> (cultures only)
	Crimean-Congo haemorrhagic fever virus
	Dengue virus (cultures only)
	Eastern equine encephalitis virus (cultures only)
	<i>Escherichia coli</i> , verotoxigenic (cultures only)
	Ebola virus
	Flexal virus
	<i>Francisella tularensis</i> (cultures only)
	Guanarito virus
	Hantaan virus
	Hantaviruses causing haemorrhagic fever with renal syndrome
	Hendra virus
	Hepatitis B virus (cultures only)
	Herpes B virus (cultures only)
	Human immunodeficiency virus (cultures only)
	Highly pathogenic avian influenza virus (cultures only)
	Japanese Encephalitis virus (cultures only)
	Junin virus
	Kyasanur Forest disease virus
	Lassa virus
	Machupo virus
Marburg virus	
Monkeypox virus	
<i>Mycobacterium tuberculosis</i> (cultures only)	
Nipah virus	
Omsk haemorrhagic fever virus	

INDICATIVE EXAMPLES OF INFECTIOUS SUBSTANCES INCLUDED IN CATEGORY A IN ANY FORM UNLESS OTHERWISE INDICATED	
	Poliovirus (cultures only)
	Rabies virus (Note: “cultures only” added by the air mode from 2005)
	<i>Rickettsia prowazekii</i> (cultures only)
	<i>Rickettsia rickettsii</i> (cultures only)
	Rift Valley fever virus (Note: “cultures only” added by the air mode from 2005)
	Russian spring-summer encephalitis virus (cultures only)
	Sabia virus
	<i>Shigella dysenteriae type 1</i> (cultures only)
	Tick-borne encephalitis virus (cultures only)
	Variola virus
	Venezuelan equine encephalitis virus (Note: “cultures only” added by the air mode from 2005)
	West Nile virus (cultures only)
	Yellow fever virus (cultures only)
	<i>Yersinia pestis</i> (cultures only)
UN 2900 Infectious substances affecting animals only	African horse sickness virus (Note: deleted by the air mode from 2005)
	African swine fever virus (Note: “cultures only” added by the air mode from 2005)
	Avian paramyxovirus Type 1 – (Note: “Velogenic” added by the air mode from 2005) Newcastle disease virus (Note: “cultures only” added by the air mode in 2005)
	Bluetongue virus (Note: deleted by the air mode from 2005)
	Classical swine fever virus (Note: “cultures only” added by the air mode from 2005)
	Foot and mouth disease virus (Note: “cultures only” added by the air mode from 2005)
	Lumpy skin disease virus (Note: “cultures only” added by the air mode from 2005)
	<i>Mycoplasma mycoides – contagious bovine pleuropneumonia</i> (Note: “cultures only” added by the air mode from 2005)
	Peste des petits ruminants virus (Note: “cultures only” added by the air mode from 2005)
	Rinderpest virus (Note: “cultures only” added by the air mode from 2005)
	Sheep-pox virus (Note: “cultures only” added by the air mode from 2005)
	Goatpox virus (Note: “cultures only” added by the air mode from 2005)
	Swine vesicular disease virus (Note: “cultures only” added by the air mode from 2005)
	Vesicular stomatitis virus (Note: “cultures only” added by the air mode from 2005)

Annex 3

Packing Instruction P620

Infectious substances in Category A and designated as UN 2814 or UN 2900 may only be transported in packaging that meets the United Nations class 6.2 specifications and complies with Packing Instruction P620 (PI602 air mode), which is reproduced below. The various provisions mentioned are set out in the United Nations Model Regulations.

P620	PACKING INSTRUCTION	P620
This instruction applies to UN Nos. 2814 and 2900.		
<p>The following packagings are authorized provided the special packing provisions of 4.1.8 are met: Packagings meeting the requirements of Chapter 6.3 and approved accordingly consisting of:</p> <p>(a) Inner packagings comprising:</p> <ul style="list-style-type: none"> (i) watertight primary receptacle(s); (ii) a watertight secondary packaging; (iii) other than for solid infectious substances, an absorbent material in sufficient quantity to absorb the entire contents placed between the primary receptacle(s) and the secondary packaging; if multiple primary receptacles are placed in a single secondary packaging, they shall be either individually wrapped or separated so as to prevent contact between them; <p>(b) A rigid outer packaging of adequate strength for its capacity, mass and intended use. The smallest external dimension shall be not less than 100 mm.</p>		
<p>Additional requirements:</p> <ol style="list-style-type: none"> 1. Inner packagings containing infectious substances shall not be consolidated with inner packagings containing unrelated types of goods. Complete packages may be overpacked in accordance with the provisions of 1.2.1 and 5.1.2; such an overpack may contain dry ice. 2. Other than for exceptional consignments, e.g. whole organs which require special packaging, the following additional requirements shall apply: <ul style="list-style-type: none"> (a) Substances consigned at ambient temperatures or at a higher temperature: Primary receptacles shall be of glass, metal or plastics. Positive means of ensuring a leakproof seal shall be provided, e.g. a heat seal, a skirted stopper or a metal crimp seal. If screw caps are used, they shall be secured by positive means, e.g., tape, paraffin sealing tape or manufactured locking closure; (b) Substances consigned refrigerated or frozen: Ice, dry ice or other refrigerant shall be placed around the secondary packaging(s) or alternatively in an overpack with one or more complete packages marked in accordance with 6.3.1.1. Interior supports shall be provided to secure secondary packaging(s) or packages in position after the ice or dry ice has dissipated. If ice is used, the outer packaging or overpack shall be leakproof. If dry ice is used, the outer packaging or overpack shall permit the release of carbon dioxide gas. The primary receptacle and the secondary packaging shall maintain their integrity at the temperature of the refrigerant used; (c) Substances consigned in liquid nitrogen. Plastics primary receptacles capable of withstanding very low temperature shall be used. The secondary packaging shall also be capable of withstanding very low temperatures, and in most cases will need to be fitted over the primary receptacle individually. Provisions for the consignment of liquid nitrogen shall also be fulfilled. The primary receptacle and the secondary packaging shall maintain their integrity at the temperature of the liquid nitrogen; (d) Lyophilized substances may also be carried in primary receptacles that are flame-sealed glass ampoules or rubber-stoppered glass vials fitted with metal seals. 3. Whatever the intended temperature of the consignment, the primary receptacle or the secondary packaging shall be capable of withstanding without leakage an internal pressure producing a pressure differential of not less than 95 kPa and temperatures in the range -40 °C to +55 °C. 		

Annex 4

Packing Instruction P650

The text of United Nations Packing Instruction 650, in use for the transport of infectious substances in category B assigned to UN 3373 by all surface modes of transport is reproduced below. The shaded text on the right hand side indicates the ICAO variations to these instructions that apply to the transport by air from 2005. The text in bold in the right hand column indicates the changes that will be adopted by the other modes of transport from 2007 and can be used now without contravening current regulations. The various provisions mentioned are set out in the United Nations Model Regulations.

P650	PACKING INSTRUCTION	P650
This packing instruction applies to UN 3373.		
		Variations applying to air transport from 2005
(1)	The packaging shall be of good quality, strong enough to withstand the shocks and loadings normally encountered during transport, including transshipment between transport units and between transport units and warehouses as well as any removal from a pallet or overpack for subsequent manual or mechanical handling. Packagings shall be constructed and closed to prevent any loss of contents that might be caused under normal conditions of transport by vibration or by changes in temperature, humidity or pressure.	
(2)	The packaging shall consist of three components: <ul style="list-style-type: none"> (a) a primary receptacle, (b) a secondary packaging, and (c) an outer packaging 	<p>The outer packaging must be rigid.</p> <p>Note: It is likely that from 2007 there will be requirement for the secondary or the outer packaging to be rigid.</p>
(3)	Primary receptacles shall be packed in secondary packagings in such a way that, under normal conditions of transport, they cannot break, be punctured or leak their contents into the secondary packaging. Secondary packagings shall be secured in outer packagings with suitable cushioning material. Any leakage of the contents shall not compromise the integrity of the cushioning material or of the outer packaging.	
(4)	For transport, the mark illustrated below shall be displayed on the external surface of the outer packaging on a background of a contrasting colour and shall be clearly visible and legible. The width of the line shall be at least 2 mm; the letters and numbers shall be at least 6 mm high.	<p>For transport, the mark illustrated below shall be displayed on the external surface of the outer packaging on a background of a contrasting colour and must be clearly visible and legible. The mark must be in the form of a square set at an angle of 45° (diamond-shaped) with each side having a length of at least 50 mm, the width of the line must be at least 2 mm, and the letters and numbers must be at least 6 mm high. The proper shipping name "DIAGNOSTIC SPECIMENS" or "CLINICAL SPECIMENS" in letters at least 6 mm high must be marked on the outer package adjacent to the diamond-shaped mark.</p> <p>Note: From 2007 the terms "DIAGNOSTIC SPECIMENS" or "CLINICAL SPECIMENS" will be replaced by "BIOLOGICAL SUBSTANCE, CATEGORY B" and this name will have to appear on all packages for all modes of transport. ICAO, being the only organization currently requiring names on these packages, has agreed that this new name can be used immediately as an alternative.</p>
		At least one surface of the outer packaging must have a

minimum dimension of 100 mm × 100 mm.	
	
(5) The completed package shall be capable of successfully passing the drop test in 6.3.2.5 as specified in 6.3.2.3 and 6.3.2.4 of these Regulations except that the height of the drop shall not be less than 1.2 m.	
(6) For liquid substances	
(a) The primary receptacle(s) shall be leakproof;	and must not contain more than 1 litre;
(b) The secondary packaging shall be leakproof;	
(c) If multiple fragile primary receptacles are placed in a single secondary packaging, they shall be either individually wrapped or separated to prevent contact between them;	
(d) Absorbent material shall be placed between the primary receptacle(s) and the secondary packaging. The absorbent material shall be in quantity sufficient to absorb the entire contents of the primary receptacle(s) so that any release of the liquid substance will not compromise the integrity of the cushioning material or of the outer packaging;	
(e) The primary receptacle or the secondary packaging shall be capable of withstanding, without leakage, an internal pressure of 95 kPa (0.95 bar).	
	(f) The outer package must not contain more than 4 litres. This quantity excludes ice, dry ice or liquid nitrogen when used to keep specimens cold.
(7) For solid substances	
(a) The primary receptacle(s) shall be siftproof;	and must not exceed the outer packaging mass limit;
(b) The secondary packaging shall be siftproof;	
(c) If multiple fragile primary receptacles are placed in a single secondary packaging, they shall be either individually wrapped or separated to prevent contact between them.	
	(d) Except for packages containing body parts, organs or whole bodies, the outer package must not contain more than 4 kg. This quantity excludes ice, dry ice or liquid nitrogen when used to keep specimens cold;
	(e) If there is any doubt as to whether or not residual liquid may be present in the primary receptacle during transport, then packaging suitable for liquids, including absorbent materials, must be used.
(8) Refrigerated or frozen specimens: Ice, dry ice and liquid nitrogen	
(a) When dry ice or liquid nitrogen is used to keep specimens cold, all applicable requirements of these Regulations shall be met. When used, ice or dry ice shall be placed outside the secondary packagings or in the outer packaging or an overpack. Interior supports shall be provided to secure the secondary packagings in the original position after the ice or dry ice has dissipated. If ice is used, the outside	

packaging or overpack shall be leakproof. If carbon dioxide, solid (dry ice) is used, the packaging shall be designed and constructed to permit the release of carbon dioxide gas to prevent a build-up of pressure that could rupture the packagings and shall be marked "Carbon dioxide, solid" or "Dry ice".

- (b) The primary receptacle and the secondary packaging shall maintain their integrity at the temperature of the refrigerant used as well as the temperatures and the pressures which could result if refrigeration were lost.

When packages are placed in an overpack, the package markings required by this packing instruction shall either be clearly visible or be reproduced on the outside of the overpack.

- (9) Infectious substances assigned to UN 3373 which are packed and marked in accordance with this packing instruction are not subject to any other requirement in these Regulations.

Infectious substances assigned to UN 3373 that are packed and marked in accordance with this packing instruction are not subject to any other requirement in these Instructions except for the following:

- (a) the proper shipping name, UN number and the name, address and telephone number of a person responsible must be provided on a written document (such as an air waybill) or on the package;
- (b) classification must be in accordance with provision 2;6.3.2 of the ICAO Technical Instructions;
- (c) the incident reporting requirements in provision 7;4.4 of the ICAO Technical Instructions must be met;
- (d) the inspection for damage or leakage requirements in provisions 7;3.1.3 and 7;3.1.4 of the ICAO Technical Instructions;
- (e) passengers and crew members are prohibited from transporting infectious substances either as, or in, carry-on baggage or checked baggage or on their person.

- (10) Clear instructions on filling and closing such packages shall be provided by packaging manufacturers and subsequent distributors to the consignor or to the person who prepares the package (e.g. patient) to enable the package to be correctly prepared for transport.

Other dangerous goods must not be packed in the same packaging as Division 6.2 infectious substances unless they are necessary for maintaining the viability, stabilizing or preventing degradation or neutralizing the hazards of the infectious substances. A quantity of 30 ml or less of dangerous goods included in Classes 3 (flammable liquids), 8 (corrosives) or 9 (miscellaneous dangerous substances and articles) may be packed in each primary receptacle containing infectious substances. When these small quantities of dangerous goods are packed with infectious substances in accordance with this packing instruction no other requirements in these Instructions need to be met.

Note: This provision is likely to be applied by all modes from 2007.

Annex 5

Flowchart for the classification of infectious substances and patient specimens

